

# Brush strip & sealing systems

A combination of quality, service & experience



# Formseal service & history



## The UK's leading supplier of brush strip seals

Formseal was established in 1987 and has a proven track record in delivering excellence every day through the skills and dedication of its employees, coupled with the quality and versatility of our products.

Our friendly and efficient service, plus attention to customer requirements, has resulted in Formseal becoming the market leader in the supply of brush strip seals. Formseal have an unrivalled reputation for quality and reliability which encourages users to repeatedly purchase our products. Our customer base is wide and varied and our products are manufactured with this in mind. With a huge range of designs for different applications, the potential of the Formseal range is unlimited.

## Friendly technical advice and support



0800 975 8004

Our dedicated technical support team are available to assist and advise on aspects of brush design.

## Order now online!

For your convenience – You can purchase **ONLINE 24/7**  
[www.formseal.co.uk](http://www.formseal.co.uk)



PayPal VISA

## Formseal hold an extensive range in stock for next working day delivery

Our fast and efficient process enables us to rapidly produce the goods for same day despatch.



Orders received by 1pm are despatched the same day for next working day delivery.

Please note: Lead times may apply for brush strip specials and customised orders.

In a hurry? No problem. Collect your order from us! Or choose a specified timed delivery (additional charges apply). Ask us about this!

Formseal are dedicated to continually improving its products and services. Whilst every effort is made to ensure details provided are correct, the company reserves the right to alter the specification to any of the products shown without prior notification.



# Index

## Standard brush strip range

Carrier 180°	4
Carrier 45°	6
Carrier 90°	8
Camstrip	10

## Brush strip specials

Brush strip with non-standard brush filaments	12
Custom slots on carrier brush strip	12

## Flexible brush strip

Profile 180° & 90°	13
Clip on profile 180° & 90°	14
Square, trapezium and clip in profile	15

## Industrial doors

Roller shutters	16
Insulated roller shutters	17
Concertina	18

## Garage doors

Rubber seals	19
--------------	----

## Domestic doors

Bottom & centre door seals	20
Centre door seal	21
Plastic coated door seal & self-adhesive brush strip	22

## Special products

Lath brush	23
Wear strip	24
Antistatic brush	24
Brush strip, coils & rings	25
Strimmer brushes	26
Domestic doormats	27



# Standard brush strip range

## Carrier 180°

Brush strips are incredibly versatile and can be customised to fit almost any application. Formseal has an unmatched selection of in-stock standard brush strips in a variety of sizes and filament material and overall lengths to meet your immediate need. Formseal's brush strip can be supplied cut to size, with fixing holes or coloured to your specification.

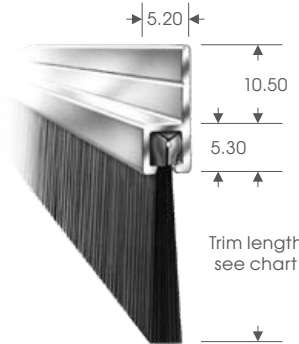

Aluminium thickness: 1.2mm

No. 1 Section - XSmall

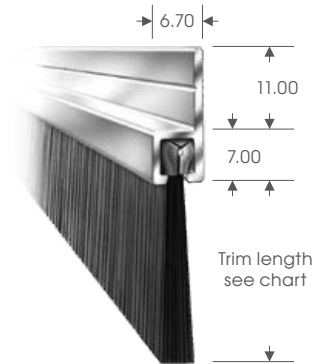

Aluminium thickness: 1.4mm

No. 2 Section - Small

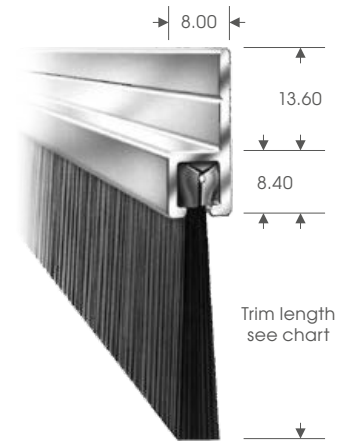

Aluminium thickness: 1.6mm

No. 3 Section - Medium

- ✓ Available in 6 section sizes with over 40 trim lengths or manufactured to customer specification.
- ✓ Carriers or camstrip can be purchased separately.
- ✓ Standard lengths: 2m, 2.5m and 3m.
- ✓ Cut lengths are available on request.

### Standard materials

Filaments – Extruded from type 6 nylon:

- Hard wearing.
- Good memory.
- Working temperature range -40°C to +100°C.

Metal backing – Electro galvanised steel.

Core wire – Electro galvanised steel.

Fixing carrier – Mill finish extruded aluminium in 180°, 90° and 45° flanges.

### Non-standard items

Non-standard seals are available to individual customer specification. These can include:

- Stainless steel backing tape.
- Metallic or natural fibre filaments.
- Coils or rings etc; made from standard or non-standard brush strip.
- Anodised or painted finishes available on request.

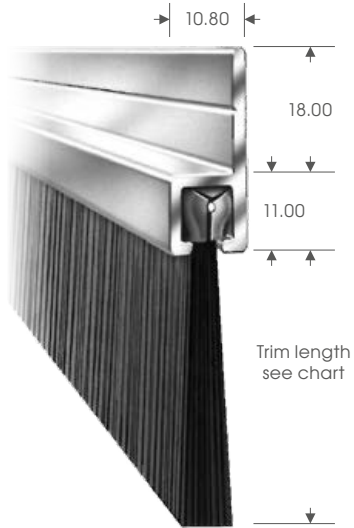

Aluminium thickness: 1.8mm

**No. 4 Section - Large**

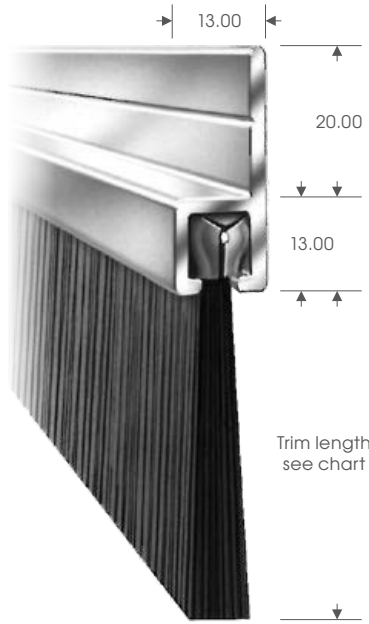

Aluminium thickness: 1.8mm

**No. 5 Section - XLarge**

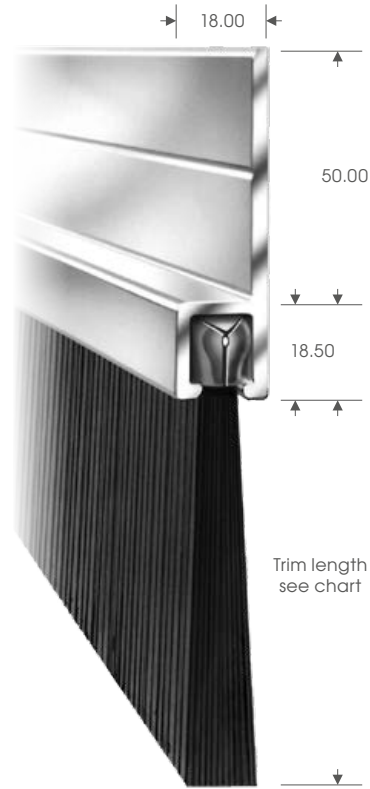

Aluminium thickness: 3.1mm

**No. 6 Section - XXL Large**



No. 1 Section - XSmall	
Trim	Ref
7mm	FS 1/7-180°
10mm	FS 1/10-180°
12mm	FS 1/12-180°
15mm	FS 1/15-180°

No. 2 Section - Small	
Trim	Ref
15mm	FS 2/15-180°
20mm	FS 2/20-180°
26mm	FS 2/26-180°
34mm	FS 2/34-180°
50mm	FS 2/50-180°

No. 3 Section - Medium	
Trim	Ref
17mm	FS 3/17-180°
20mm	FS 3/20-180°
26mm	FS 3/26-180°
34mm	FS 3/34-180°
40mm	FS 3/40-180°
44mm	FS 3/44-180°
50mm	FS 3/50-180°
75mm	FS 3/75-180°
100mm	FS 3/100-180°

No. 4 Section - Large	
Trim	Ref
26mm	FS 4/26-180°
43mm	FS 4/43-180°
50mm	FS 4/50-180°
75mm	FS 4/75-180°
102mm	FS 4/102-180°

No. 5 Section - XLarge	
Trim	Ref
46mm	FS 5/46-180°
50mm	FS 5/50-180°
66mm	FS 5/66-180°
80mm	FS 5/80-180°
102mm	FS 5/102-180°
125mm	FS 5/125-180°
150mm	FS 5/150-180°
180mm	FS 5/180-180°

No. 6 Section - XXL Large	
Trim	Ref
210mm	FS 6/210-180°
250mm	FS 6/250-180°
300mm	FS 6/300-180°

Measurements are in mm and have a tolerance +/- and are provided as a guide only. All specifications are subject to change at any time without prior notification.

# Standard brush strip range

## Carrier 45°

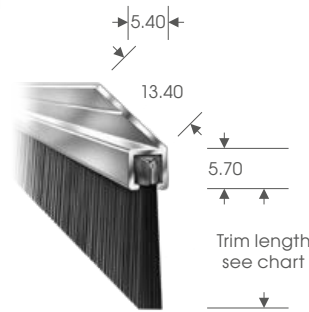

Aluminium thickness: 1.3mm

No. 1 Section - XSmall

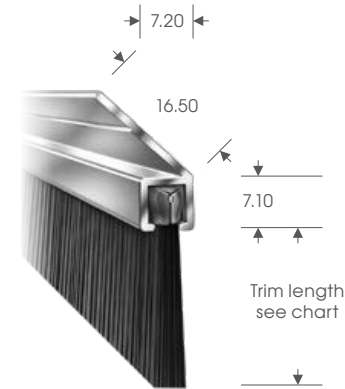

Aluminium thickness: 1.7mm

No. 2 Section - Small

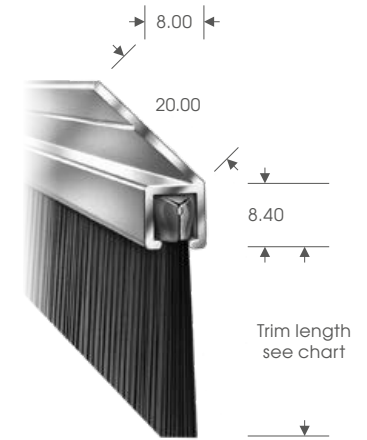

Aluminium thickness: 1.6mm

No. 3 Section - Medium

- ✓ Available in 6 section sizes with over 40 trim lengths or manufactured to customer specification.
- ✓ Carriers or camstrip can be purchased separately.
- ✓ Standard lengths: 2m, 2.5m and 3m.
- ✓ Cut lengths are available on request.

### Standard materials

**Filaments** – Extruded from type 6 nylon:

- Hard wearing.
- Good memory.
- Working temperature range -40°C to +100°C.

**Metal backing** – Electro galvanised steel.

**Core wire** – Electro galvanised steel.

**Fixing carrier** – Mill finish extruded aluminium in 180°, 90° and 45° flanges.

### Non-standard items

Non-standard seals are available to individual customer specification. These can include:

- Stainless steel backing tape.
- Metallic or natural fibre filaments.
- Coils or rings etc; made from standard or non-standard brush strip.
- Anodised or painted finishes available on request.

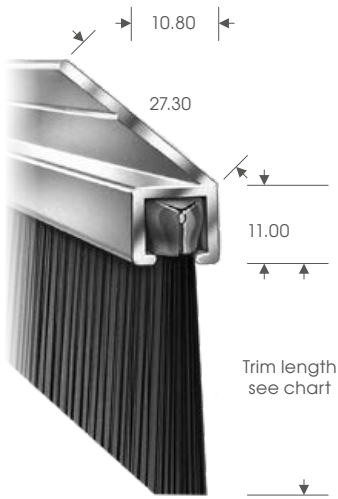

Aluminium thickness: 2.1mm

**No. 4 Section - Large**

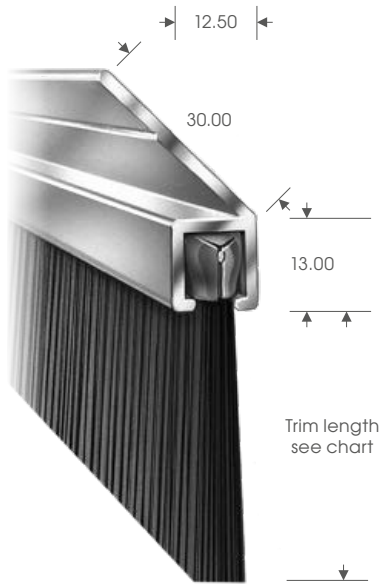

Aluminium thickness: 1.9mm

**No. 5 Section - XLarge**

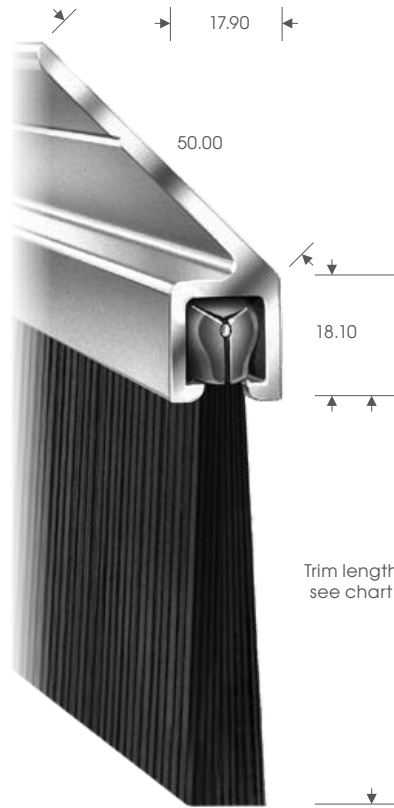

Aluminium thickness: 3.0mm

**No. 6 Section - XXL Large**



No. 1 Section - XSmall	
Trim	Ref
7mm	FS 1/7-45°
10mm	FS 1/10-45°
12mm	FS 1/12-45°
15mm	FS 1/15-45°

No. 2 Section - Small	
Trim	Ref
15mm	FS 2/15-45°
20mm	FS 2/20-45°
26mm	FS 2/26-45°
34mm	FS 2/34-45°
50mm	FS 2/50-45°

No. 3 Section - Medium	
Trim	Ref
17mm	FS 3/17-45°
20mm	FS 3/20-45°
26mm	FS 3/26-45°
34mm	FS 3/34-45°
40mm	FS 3/40-45°
44mm	FS 3/44-45°
50mm	FS 3/50-45°
75mm	FS 3/75-45°
100mm	FS 3/100-45°

No. 4 Section - Large	
Trim	Ref
26mm	FS 4/26-45°
43mm	FS 4/43-45°
50mm	FS 4/50-45°
75mm	FS 4/75-45°
102mm	FS 4/102-45°

No. 5 Section - XLarge	
Trim	Ref
46mm	FS 5/46-45°
50mm	FS 5/50-45°
66mm	FS 5/66-45°
80mm	FS 5/80-45°
102mm	FS 5/102-45°
125mm	FS 5/125-45°
150mm	FS 5/150-45°
180mm	FS 5/180-45°

No. 6 Section - XXL Large	
Trim	Ref
210mm	FS 6/210-45°
250mm	FS 6/250-45°
300mm	FS 6/300-45°

Measurements are in mm and have a tolerance +/- and are provided as a guide only. All specifications are subject to change at any time without prior notification.

# Standard brush strip range

## Carrier 90°

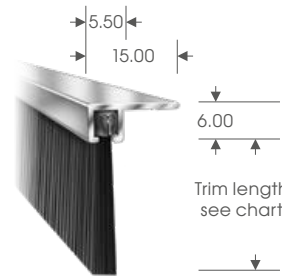

Aluminium thickness: 1.4mm

No. 1 Section - XSmall

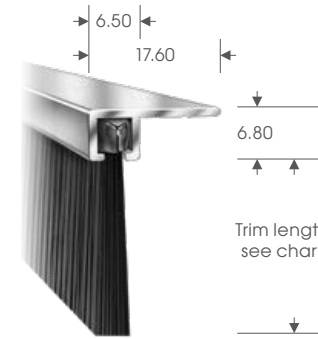

Aluminium thickness: 1.5mm

No. 2 Section - Small

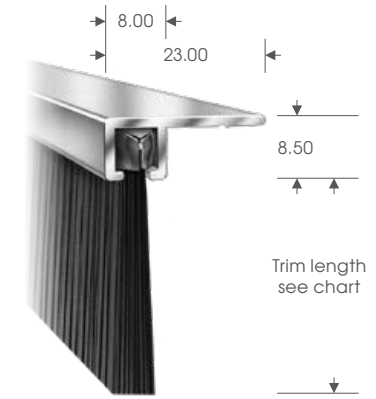

Aluminium thickness: 1.6mm

No. 3 Section - Medium

- ✓ Available in 6 section sizes with over 40 trim lengths or manufactured to customer specification.
- ✓ Carriers or camstrip can be purchased separately.
- ✓ Standard lengths: 2m, 2.5m and 3m.
- ✓ Cut lengths are available on request.

### Standard materials

**Filaments** – Extruded from type 6 nylon:

- Hard wearing.
- Good memory.
- Working temperature range -40°C to +100°C.

**Metal backing** – Electro galvanised steel.

**Core wire** – Electro galvanised steel.

**Fixing carrier** – Mill finish extruded aluminium in 180°, 90° and 45° flanges.

### Non-standard items

Non-standard seals are available to individual customer specification. These can include:

- Stainless steel backing tape.
- Metallic or natural fibre filaments.
- Coils or rings etc; made from standard or non-standard Brush Strip.
- Anodised or painted finishes available on request.



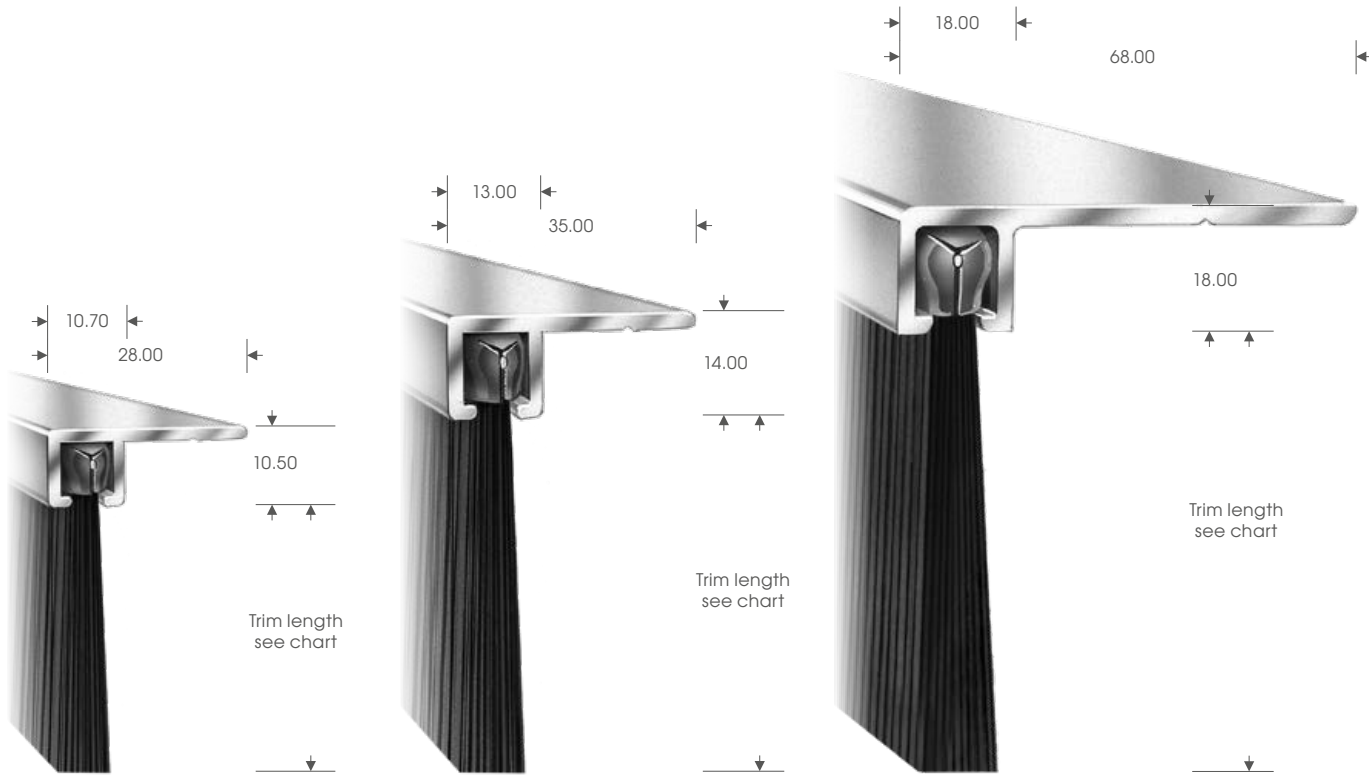

Aluminium thickness: 2.1mm

**No. 4 Section - Large**

Aluminium thickness: 1.9mm

**No. 5 Section - XLarge**

Aluminium thickness: 3.2mm

**No. 6 Section - XXL Large**

No. 1 Section - XSmall	
Trim	Ref
7mm	FS 1/7-90°
10mm	FS 1/10-90°
12mm	FS 1/12-90°
15mm	FS 1/15-90°

No. 2 Section - Small	
Trim	Ref
15mm	FS 2/15-90°
20mm	FS 2/20-90°
26mm	FS 2/26-90°
34mm	FS 2/34-90°
50mm	FS 2/50-90°

No. 3 Section - Medium	
Trim	Ref
17mm	FS 3/17-90°
20mm	FS 3/20-90°
26mm	FS 3/26-90°
34mm	FS 3/34-90°
40mm	FS 3/40-90°
44mm	FS 3/44-90°
50mm	FS 3/50-90°
75mm	FS 3/75-90°
100mm	FS 3/100-90°

No. 4 Section - Large	
Trim	Ref
26mm	FS 4/26-90°
43mm	FS 4/43-90°
50mm	FS 4/50-90°
75mm	FS 4/75-90°
102mm	FS 4/102-90°

No. 5 Section - XLarge	
Trim	Ref
46mm	FS 5/46-90°
50mm	FS 5/50-90°
66mm	FS 5/66-90°
80mm	FS 5/80-90°
102mm	FS 5/102-90°
125mm	FS 5/125-90°
150mm	FS 5/150-90°
180mm	FS 5/180-90°

No. 6 Section - XXL Large	
Trim	Ref
210mm	FS 6/210-90°
250mm	FS 6/250-90°
300mm	FS 6/300-90°

Measurements are in mm and have a tolerance +/- and are provided as a guide only. All specifications are subject to change at any time without prior notification.



# Standard brush strip range

## Camstrip

If you do not find your brush size or filament in this brochure, please do not hesitate to contact us, as our expert staff shall be pleased to advise and assist you with your requirements.

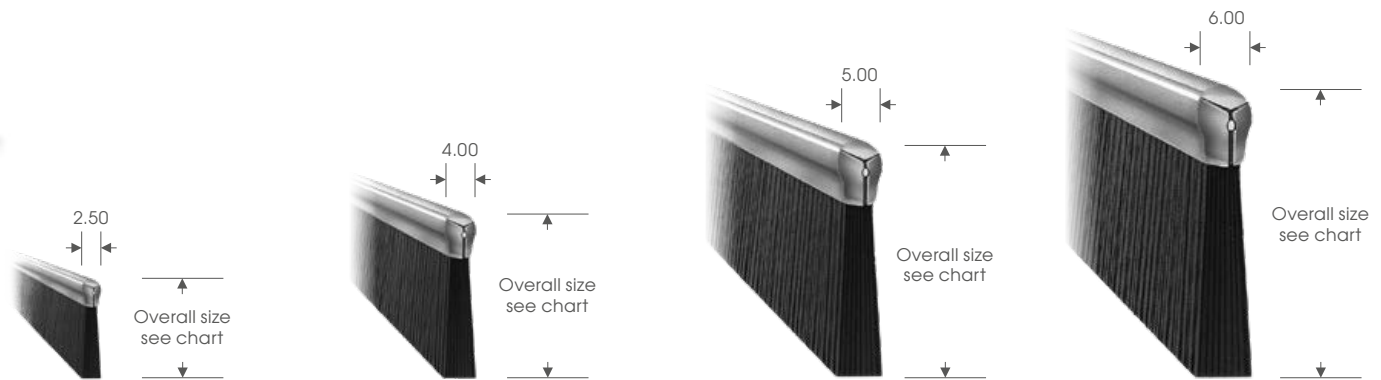

No. 1 Section - XSmall

No. 2 Section - Small

No. 3 Section - Medium

No. 4 Section - Large

- ✓ Available in 6 section sizes with over 40 trim lengths or manufactured to customer specification.
- ✓ For use where our aluminium fixing carrier is not required.
- ✓ Standard lengths: 2m, 2.5m and 3m.
- ✓ Cut lengths are available on request.

### Standard materials

**Filaments** – Extruded from type 6 nylon:

- Hard wearing.
- Good memory.
- Working temperature range -40°C to +100°C.
- Non-standard filaments include; horse hair, polypropylene, natural fibre or metallic.

**Metal backing** – Electro galvanised steel (stainless steel available on request).

**Core wire** – Electro galvanised steel (stainless steel available on request).

No. 1 Section - XSmall			
Overall	Ref	W	Fill*
12mm	CS1/12	2.50	0.15
14mm	CS1/14	2.50	0.15
16mm	CS1/16	2.50	0.15
19mm	CS1/19	2.50	0.15

*Measurements are in mm and have a tolerance +/- and are provided as a guide only.  
All specifications are subject to change at any time without prior notification.  
\* Bristle diameter. Fill material: Nylon 6.*

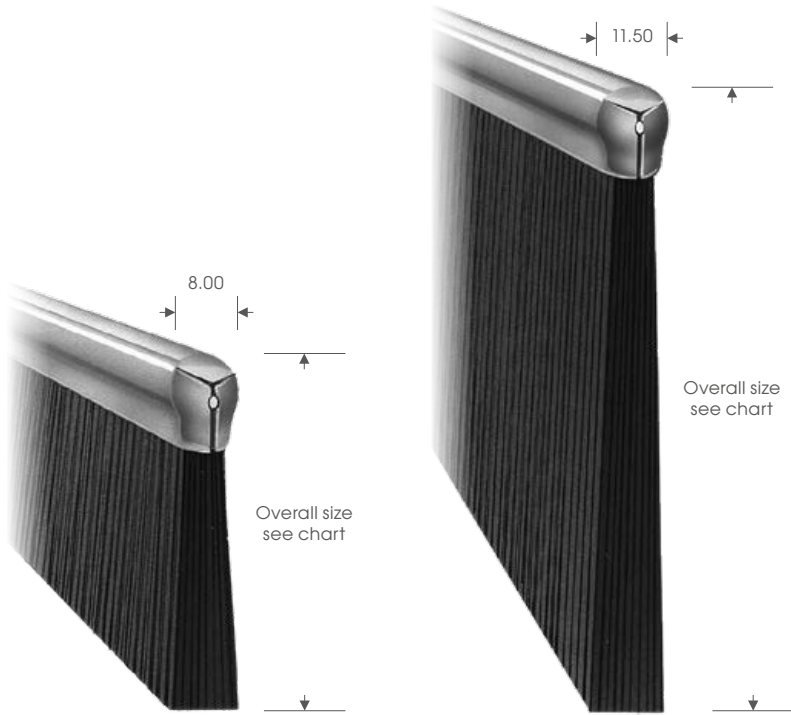

**No. 5 Section - XLarge**

**No. 6 Section - XXLLarge**

No. 2 Section - Small			
Overall	Ref	W	Fill*
20mm	CS2/20	4.00	0.15
25mm	CS2/25	4.00	0.15
32mm	CS2/32	4.00	0.15
40mm	CS2/40	4.00	0.15
56mm	CS2/56	4.00	0.15

No. 3 Section - Medium			
Overall	Ref	W	Fill*
24mm	CS3/24	5.00	0.15
27mm	CS3/27	5.00	0.15
33mm	CS3/33	5.00	0.20
40mm	CS3/40	5.00	0.20
46mm	CS3/46	5.00	0.20
50mm	CS3/50	5.00	0.20
56mm	CS3/56	5.00	0.20
81mm	CS3/81	5.00	0.25
106mm	CS3/106	5.00	0.30

No. 4 Section - Large			
Overall	Ref	W	Fill*
33mm	CS4/33	6.00	0.20
51mm	CS4/51	6.00	0.30
57mm	CS4/57	6.00	0.20
82mm	CS4/82	6.00	0.30
109mm	CS4/109	6.00	0.40

No. 5 Section - XLarge			
Overall	Ref	W	Fill*
57mm	CS5/57	8.00	0.50
61mm	CS5/61	8.00	0.40
77mm	CS5/77	8.00	0.30
91mm	CS5/91	8.00	0.40
113mm	CS5/113	8.00	0.50
136mm	CS5/136	8.00	0.50
161mm	CS5/161	8.00	0.50
191mm	CS5/191	8.00	0.60

No. 6 Section - XXLLarge			
Trim	Ref	W	Fill*
225mm	CS6/225	11.50	0.90
265mm	CS6/265	11.50	0.90
315mm	CS6/315	11.50	1.20

# Brush strip specials

Non-standard brush filaments are available on request and may include special trim fills including fibre, metallic, horse hair, polypropylene, copper wire to name a few.

- Fixing carriers can be powder coated / anodised to your requirements.
- Non-standard brush filaments are available on request. Please contact our technical team to discuss your requirements.



Non-standard brush filaments available on request



## Custom slots on carrier brush strip

Fixing carriers can be supplied with custom slots, both round and obround mounting holes between 3.2mm and 22mm diameter.

- Custom space between the slots.
- Obround slots can be centre or on the top of the fixing carrier.
- Sample may be provided to your drawing / specification prior to production run.
- Please contact our technical team to discuss your requirements.

*Customised orders are non-returnable.*

# Flexible brush strip

## Profile 180° & 90°

Flexible brush strip easily adapts to each shape thanks to its flexible profile. It can be used for multiple applications, which including sealing, guiding, wiping, slowing down and pressing.

### Core materials:

- The standard core material is thermoplastic rubber
- Polypropylene 0.2 (standard filament)

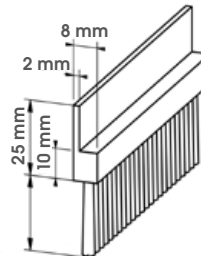
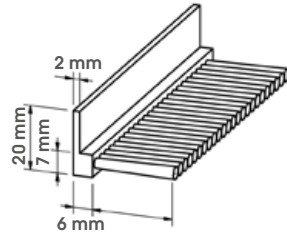
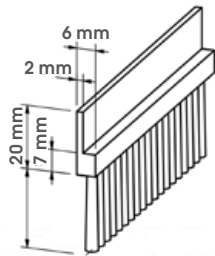

"H" Profile 180°	
Trim	Ref (583)
20mm	FSH2020
30mm	FSH2030
40mm	FSH2040
50mm	FSH2050

"F" Profile 90°	
Trim	Ref (584)
20mm	FSH920
30mm	FSH930
40mm	FSH940
50mm	FSH950

"H" Profile 180°	
Trim	Ref (585)
20mm	FSH20
30mm	FSH30
40mm	FSH40
50mm	FSH50

*Polypropylene 0.2 (standard filament)*

All profiles are delivered in convenient 25 metre rolls for you to cut to the length you need.



- ✓ Available in 25 metre lengths
- ✓ Available in several different profiles
- ✓ Available in four different brush trim lengths: 20mm, 30mm, 40mm and 50mm
- ✓ Available from stock, ex works



# Flexible brush strip

## Clip on profile 180° & 90°

Flexible brush strip easily adapts to each shape thanks to its flexible profile. It can be used for multiple applications, which including sealing, guiding, wiping, slowing down and pressing.

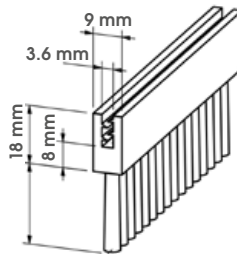

Clip On Profile 180°	
Trim	Ref (589)
20mm	FSC3620
30mm	FSC3630
40mm	FSC3640
50mm	FSC3650

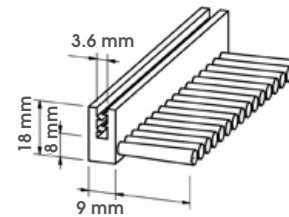

Clip On Profile 90°	
Trim	Ref (590)
20mm	FSC93620
30mm	FSC93630
40mm	FSC93640
50mm	FSC93650

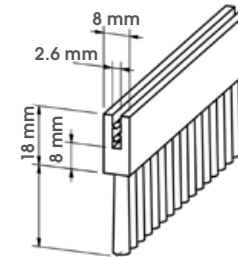

Clip On Profile 180°	
Trim	Ref (591)
20mm	FSC20
30mm	FSC30
40mm	FSC40
50mm	FSC50

Polypropylene 0.2 (standard filament)

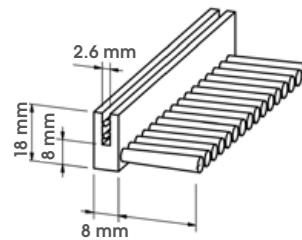

Clip On Profile 90°	
Trim	Ref (592)
20mm	FSC92620
30mm	FSC92630
40mm	FSC92640
50mm	FSC92650

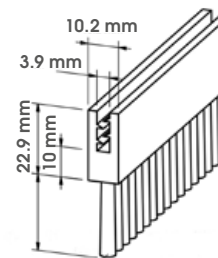

Clip On Profile 180°	
Trim	Ref (593)
20mm	FSC3920
30mm	FSC3930
40mm	FSC3940
50mm	FSC3950

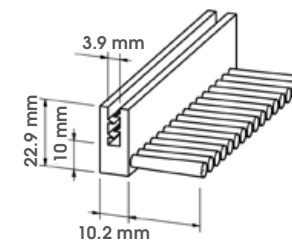

Clip On Profile 90°	
Trim	Ref (594)
20mm	FSC93920
30mm	FSC93930
40mm	FSC93940
50mm	FSC93950

Polypropylene 0.2 (standard filament)

# Flexible brush strip

## Square, trapezium and clip in profile

Flexible tufted brush strips that adapt easily to any profile. Constructed with a flexible thermoplastic core supplied with polypropylene filament material, this product is ideal for sealing, guiding, wiping and pressing.

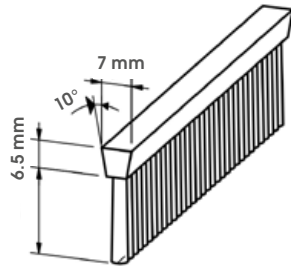

"V" Trapezium Profile	
Trim	Ref (581)
20mm	Trapezium20
30mm	Trapezium30
40mm	Trapezium40
50mm	Trapezium50

Polypropylene 0.2 (standard filament)

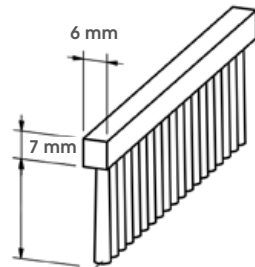

Square Profile	
Trim	Ref (582)
20mm	FSQ20
30mm	FSQ30
40mm	FSQ40
50mm	FSQ50

### Assembly

- Cut to length using wire cutters.  
Cut to any length you wish with no wastage.  
There are various methods for fixing;
1. Double-sided adhesive tape
  2. Screws
  3. Glue
  4. Slide into the 'existing' profile

Contact us for a free sample!

### Advantages

- Very flexible brush, which follows each shape effortlessly
- Manufactured from durable and high-quality thermoplastic rubber
- UV and ozone resistant, chemical resistant and resistant to temperatures from -40° to maximum 125°C
- You can cut the right size yourself due to a special opening in the box
- Less storage needed thanks to a flat stackable box
- Cost saving on transport (multiple boxes can be shrink wrapped together as one consignment)

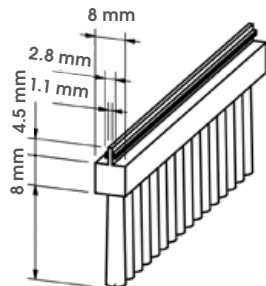

Clip In Profile 180°	
Trim	Ref (596)
20mm	Antenna20
30mm	Antenna30
40mm	Antenna40
50mm	Antenna50

Polypropylene 0.2 (standard filament)

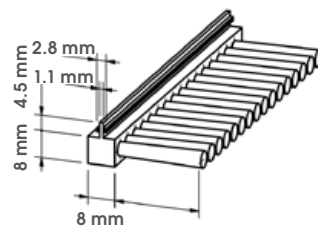

Clip In Profile 90°	
Trim	Ref (597)
20mm	Antenna920
30mm	Antenna930
40mm	Antenna940
50mm	Antenna950



The very nature of Formseal's flexible brush range will help you to find a solution to any sealing problem you may have.



# Industrial doors

## Roller shutters



- Clip on brushseal for roller shutter and door guide channels.
- Profiled door sections effectively sealed by independent movement of brush filaments.
- Simple fitting – No mechanical fixings required.
- Low friction seal for smooth operation of roller doors.
- Prevents draughts and door vibration.

### Sides – Rollerseal - Available in black and white

Clip on PVCU carrier with 34mm trim height (standard) or 50mm trim height (option) – No mechanical fixings. Prevents draughts, door vibration etc. Supplied in a 3m length.



Ref: Rollerseal black and rollerseal white

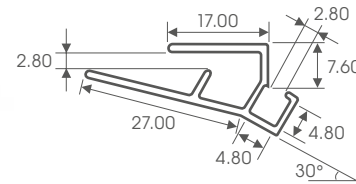

### Top – Brushseal

standard straight brush strip. Fitted to overhead lintel to seal to the face of the door. See our standard brush strip range.

### Bottom – Alternative when T-bar absence

Galvanised metal section IDUC & rubber seal IDR23 can be used as an alternative to the bumpseal product. The IDR23 can be purchased in any length (m) up to a maximum of a 50m roll.



Ref: IDUC

Ref: IDR23

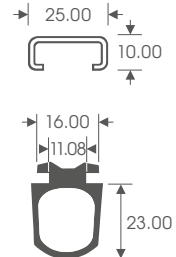

### Bottom – Bumpseal

Clip on EPDM rubber 'D' section (available in 2 types) – no mechanical fitting required. Supplied in rolls of: 5m, 10m, 20m and 40m. Fits up to 75mm T-bar.



Ref: RB5, RB10 and RB20



Ref: RB10N, RB20N and RB40\*

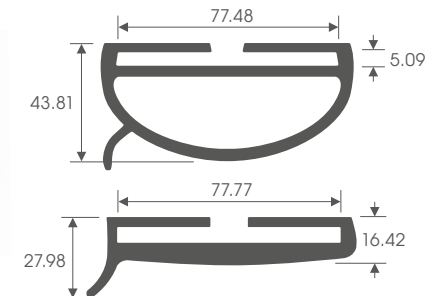

Measurements are in mm.



A variety of sealing solutions for all types of doors



# Industrial doors

## Insulated roller shutters



- Clip on pile seal for insulated roller shutter guide channels.
- Simple fitting – No mechanical fixings required.
- Low friction seal for smooth operation of Insulated roller doors.
- Prevents draughts and door vibration.

Ref: ISDS



Supplied in 3m length.

Ref: ISDS/A



Supplied in 3.2m length.



Ref: ISDS

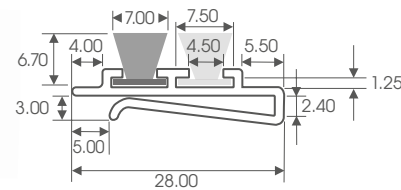

Pile seal height 5mm. Overall height 6.8mm.



Ref: ISDS/A

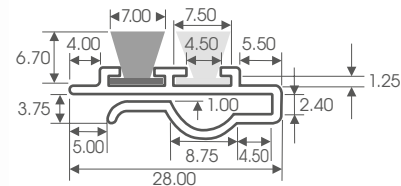

Pile seal height 5mm. Overall height 6.8mm.



Ref: IDCC

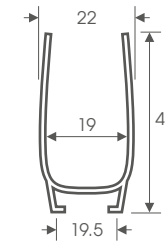

IDCC

Clip on to the bottom of insulated roller doors.

IDR23 is designed to slide in to the carrier to seal the bottom of the door. Simple fitting – Just clips on, no mechanical fixings required. Prevents draughts and door vibration.



Ref: IDR23

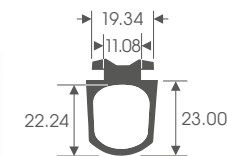

Measurements are in mm.

# Industrial doors

## Concertina



**Concertina door kits**  
Specially manufactured kits individually tailored to suit any size or make of door, suitable to seal top and bottom.

Individually assembled kits designed to seal most makes of concertina/folding shutter doors. Each kit contains pre-cut and punched lengths of Formseal No. 3 section and specially formed nose pieces suitable for sealing the top and bottom of concertina/folding shutter doors.

Kits are available in 20mm, 34mm and 50mm brush trim lengths. All products are aluminium mill finish. Brushes are black with nylon 6 filament. Panels are available in 3 sizes; 6" (150mm), 9" (230mm) or 12" (300mm).

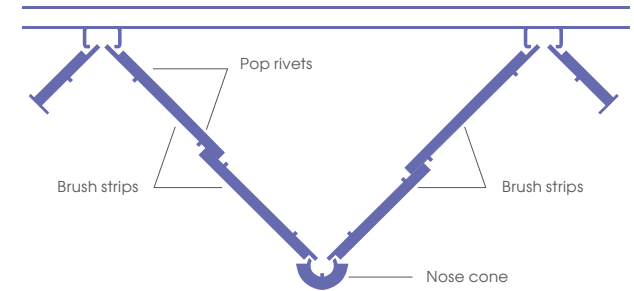

### Specify your order

- Choose your size 6" (150mm), 9" (230mm), 12" (300mm).
- How many panels do you need?
- Choose your nose cone style and quantity.
- Shape of door.
- Depth of gap 20mm, 34mm, 50mm.

Concertina panels			
Depth of gap	Ref		
	6" (150mm)	9" (230mm)	12" (300mm)
20mm	CK620	CK920	CK1220
34mm	CK634	CK934	CK1234
50mm	CK650	CK950	CK1250

### Nose cone styles

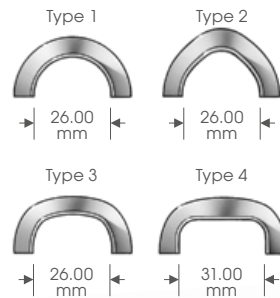

### Brush strips

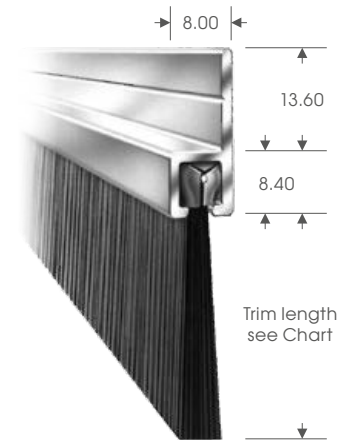

Aluminium thickness: 1.6mm

No. 3 Section - Medium



# Garage doors

## Rubber seals



Top of garage door.



Bottom of garage door.



Floor and bottom of garage door.

### Rubber seal - RS

Like the brush strip range, we are able to offer an aluminium carrier complete with rubber insert for your garage doors.

- Ideal seal for top and bottom of garage doors.
- Long service life weather seals which withstand hot/cold extreme temperatures.
- EPDM Rubber inserts for our No. 3 section carrier:

No. 3 section - **30mm** trim out with a thickness of 2.5mm:

- Ref: RS3/30-180°
- Ref: RS3/30-45°
- Ref: RS3/30-90°

No. 3 section - **55mm** trim out with a thickness of 3mm:

- Ref: RS3/55-180°
- Ref: RS3/55-45°
- Ref: RS3/55-90°

- Aluminium standard lengths in 2m, 2.5m and 3m.
- Rubber can be supplied in a continuous length up to 25m.

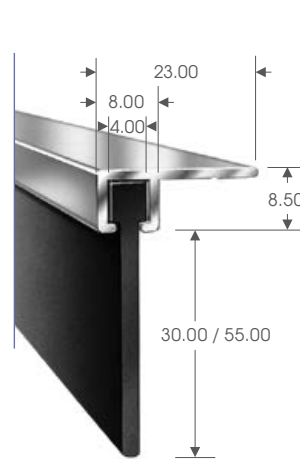

Rubber seal 90°

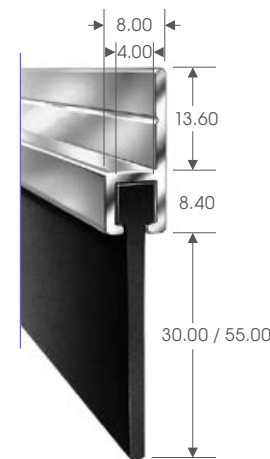

Rubber seal 180°

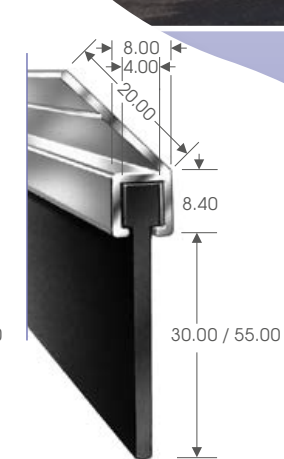

Rubber seal 45°

### Garage door seal - GDS

This garage door floor threshold seal is ideal for domestic and commercial garage doors. 20mm depth, this versatile and quality product provides you with a flexible sealing solution. Maximum length we can supply in a complete roll is 25m. Price per metre.



Ref: GDS



A range of weather seals for up and over garage doors



# Domestic doors

## Bottom & centre door seals



### Bottom door seals

- Formseal no. 2 section available in 4 trim lengths.
- Housed in pre-slotted aluminium fixing carrier.
- 914mm (36 inches).

Ref: BDA36/20 (26mm)  
BDA36/34 (34mm)  
BDA36/44 (44mm)  
BDA36/50 (50mm)

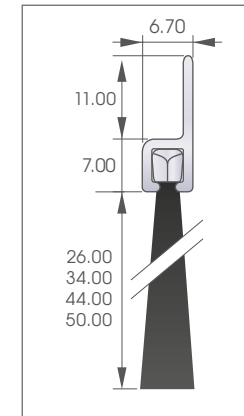

### Centre door seal

- Rebated door seal for situations where a surface mounted fix is unacceptable.
- Length 2.1m.
- Brush trim available in 4 trim lengths: 8mm, 10mm, 12mm or 15mm.

Ref: CSN157/1

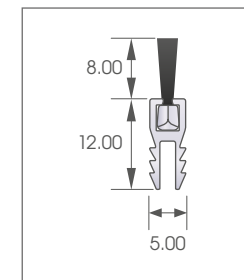

# Domestic doors

## Centre door seals

### Rebate channels

- Rebated door seals for situations where a surface mounted fix is unacceptable.
- Length 3m

Rebate 1 - 7mm  
10mm  
12mm  
15mm

Rebate 2 - 15mm  
20mm  
26mm  
34mm  
50mm

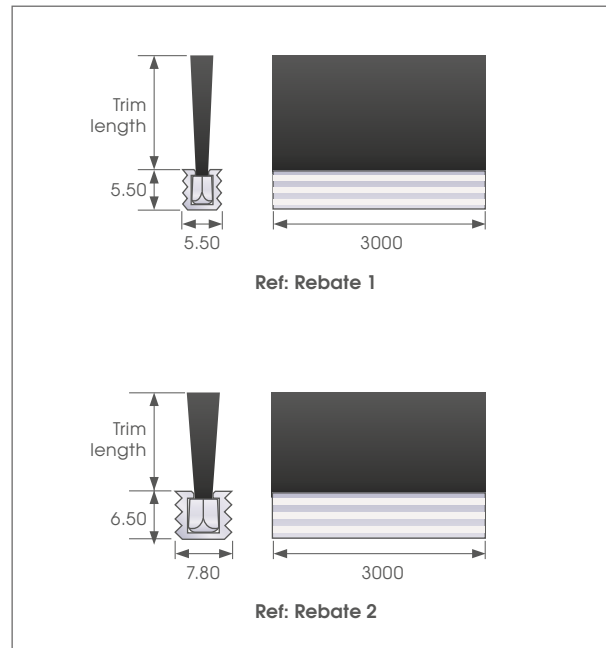

# Domestic doors

## Plastic coated door seal & self-adhesive brush strip



### Plastic coated door seal

- Formseal plastic coated door seal available in 1 trim length, 15mm.
- Housed in pre-slotted aluminium fixing carrier.
- 1-metre (39 inches).
- Available in three colour options: white, brown or brass.
- Includes end caps

Ref: BDS15 (COLOUR\*)

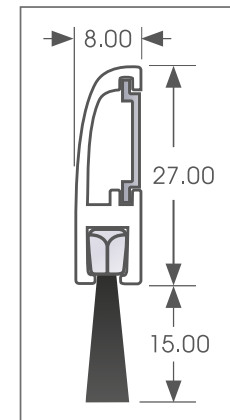

### Self-adhesive brush strip

- Formseal plastic coated door seal available in 1 trim length, 15mm.
- Housed in pre-slotted aluminium fixing carrier.
- 925mm & 1025mm.
- Its unique curved front design adds a touch of elegance.
- Includes end caps

Ref: Striboluxa1025mm  
Striboluxa925mm

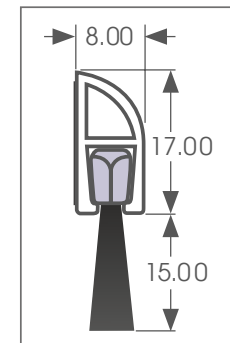

# Special products

## Lath brush

Plastic section with filaments punched directly into the stock, designed to fit on working table surfaces. This allows fragile items, such as sheets of glass, to be handled without scratching. The lath carrier is made of galvanized steel. Available in both black and white bristles.

Lath brushes are intelligent systems that enhance production efficiency. They are supplied in 2m lengths. The **lath brush** and **lath carrier** must be purchased separately, priced as individual items, and are **available from stock**.

**Lath brush - Ref: LB37**  
**Lath carrier - Ref: LC37**

*LB37 and LC37 can be purchased separately.*

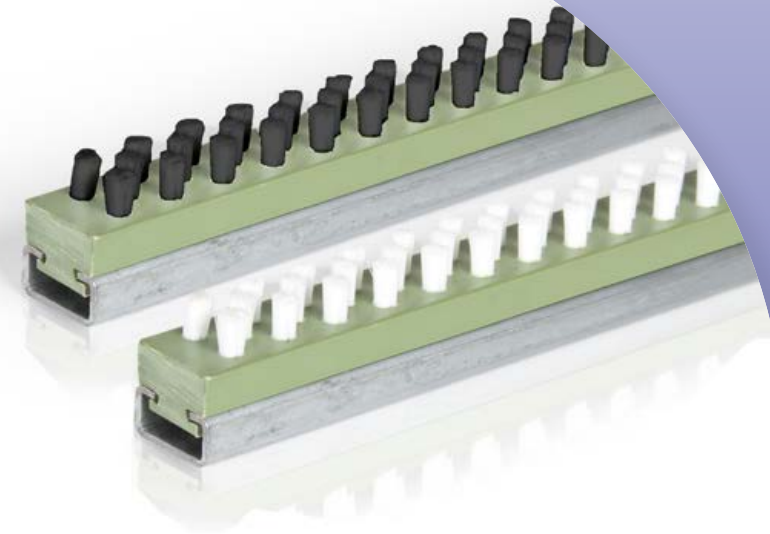
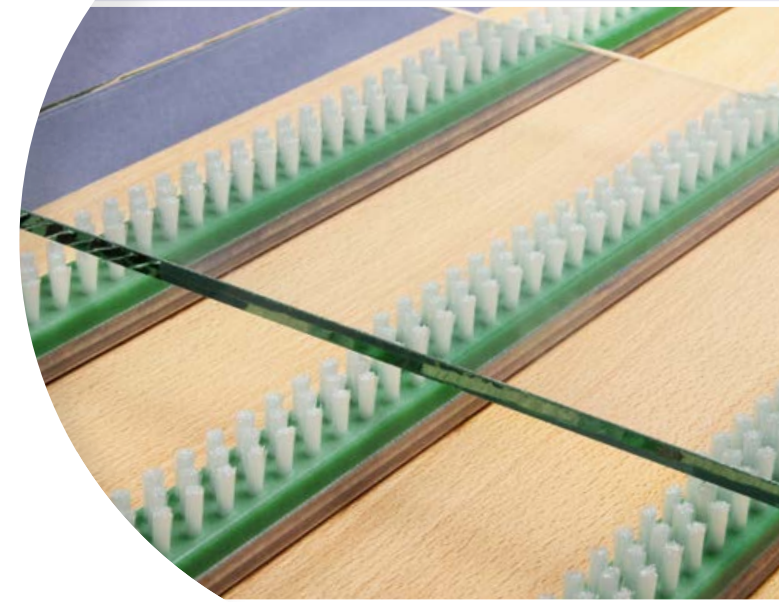
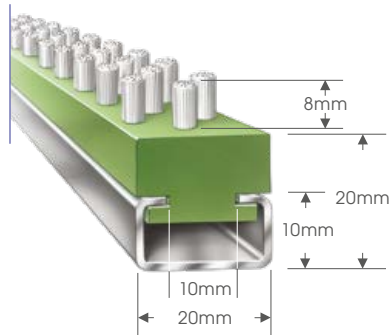

# Special products

## Wear strip

Wear strip - Ref: LGWS18117  
Lath carrier - Ref: LC37

*LGWS18117 and LC37 can be purchased separately.*

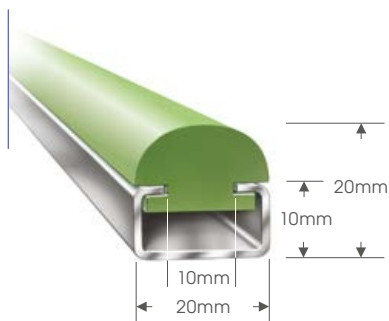

Made from high-quality PEA 500, this 2-meter wear strip offers excellent wear resistance, low friction, and superior impact strength. This wear strip is ideal for use in the window industry and for transporting sensitive parts in kitchen manufacturing, ensuring surfaces are not scratched.

The half-round profile with a T-slot or U-slot base ensures easy installation and stable positioning. You can purchase the profile separately or together with a carrier, and are **available from stock**. The lath carrier is made of galvanized steel.

## Antistatic brush

Manufactured using stainless steel yarn and carbon fibre, ideal for discharging static energy. Hairs can be cut to length.

Available in 2 types: **stainless steel yarn** or **carbon fibre antistatic brushes**, supplied in 1m lengths with a 15mm trim, and **available from stock**.

Both with an integral backing tape.

Ref: ASSS1510

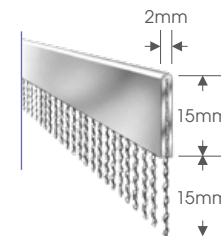

Ref: ASCF1510

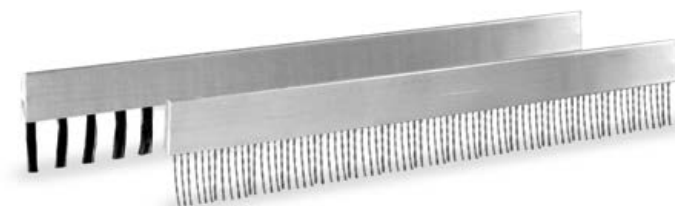
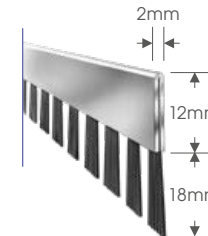



# Special products made to order

## Brush strip, coils & rings

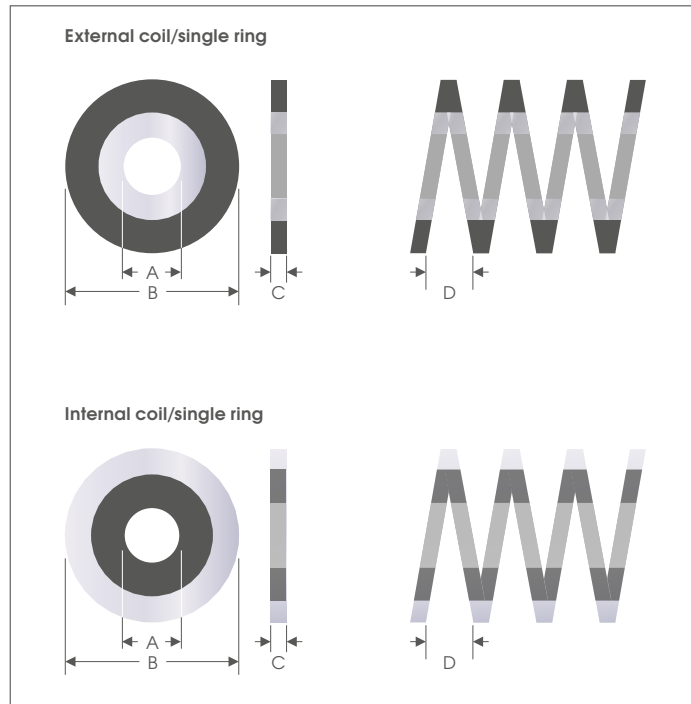

### External & internal coils/single rings

- **A** Inside diameter  $\varnothing$  ...mm
- **B** Outside diameter  $\varnothing$  ...mm
- **C** Profile width ...mm
- **D** Brush pitch ...mm

Please contact our technical team to discuss your requirements.

Formseal offer numerous special products such as lath brushes, antistatic brushes, flexible brush strip and more.

If you have a specific enquiry, then feel free to get in touch, and we will do our best to help you!

Free, no obligation quotation. Contact us TODAY!



### Formseal can assist in a variety of speciality products like:

- Cup brushes
- Formed sections – with or without aluminium carrier.
- Special trim fills – fibre / metallic / horse hair etc.

### Information required:

- Application
- Brush type / fill material
- Carrier finish
- Section / profile size
- Outside diameter
- Inside diameter
- Degree of segment

Please contact our technical team to discuss your requirements.  
\*Allow lead times as these are non standard\*

# Special products

## Strimmer brush synthetic wires



Our strimmer brush synthetic wires has been specially designed to clear kerbs and pavements, patios, driveways from weeds. It is also very effective with moss removal. Due to the synthetic wires, the brush is spark-free.

All of our strimmer brushes are fitted out with a mounting pin of 25.4mm but includes an adapter as standard for reducing an axle hole to 20mm.

**Brush diameter 170 mm - Ref: FSSB238**

**Brush diameter 200 mm - Ref: FSSB236**

*Our strimmer brush with synthetic flat wires is produced with polypropylene.*

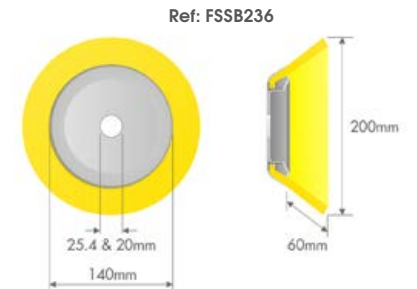
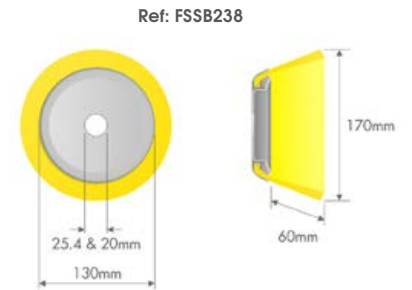

## Strimmer brush steel wire knot

Our strimmer brush twisted steel wire knot is specially designed to clear kerbs and pavements, patios, driveways of weeds. The twisted steel wires are suitable for removing stubborn weeds.

All of our strimmer brushes are fitted out with a mounting pin of 25.4mm and includes an adapter as standard for reducing an axle hole to 20mm.

**Brush diameter 150 mm - Ref: FSSB237**

**Brush diameter 200 mm - Ref: FSSB235**

*Our strimmer brushes are produced with twisted steel wire tufts.*

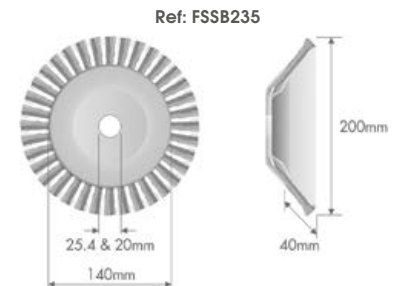
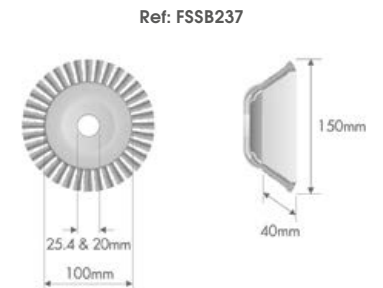

# Special products

## Domestic doormats

Our premium domestic doormat, available in different colours and 3 different sizes, features a durable aluminium finish or satin black finish and is expertly crafted for long-lasting quality.

Its UV-resistant properties ensure the color stays vibrant, while its water-resistant design makes it ideal for all weather conditions, including rain and snow. Perfect for home use, this doormat is both flexible and easy to clean, even with a pressure washer. Elevate your entrance with a doormat that seamlessly combines style, functionality, and durability.

### Dimensions

Available in 3 different sizes:

- 40 x 60cm
- 45 x 75cm
- 50 x 80cm

### Colour options

- Black/white mottled
- Black
- Grey
- Brown
- Blue
- Red
- Green
- Beige
- Lime green

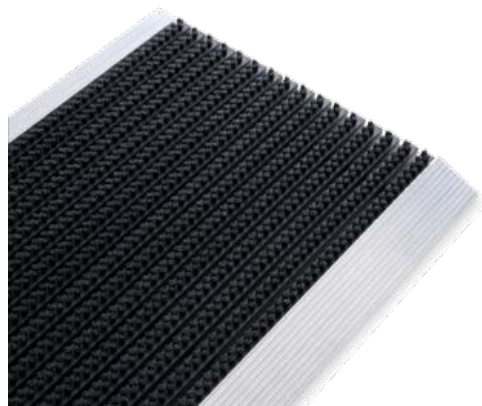

Aluminium finish - Ref: BSM/12A (COLOUR CODE/SIZE)

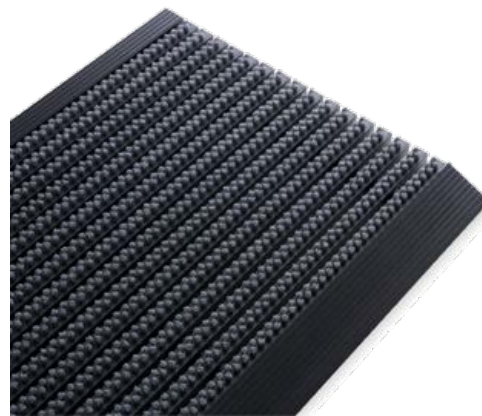

Satin black Finish - Ref: BSM/12S- (COLOUR CODE/SIZE)

Available in  
multiple colours



Formseal Limited are the market leader  
in supply of Brush Strip Seals and ancillary products.

## Formseal Limited

Unit 5  
Douglas Park  
Opal Way  
Stone Business Park  
Stone ST15 0YJ  
United Kingdom

Tel: +44 (0)1785 284808  
Email: [sales@formseal.co.uk](mailto:sales@formseal.co.uk)

[www.formseal.co.uk](http://www.formseal.co.uk)

